

MODUS FOCUSED ESWT



FOCUSED SHOCKWAVE THERAPY

CAT.1.1.1, First Release Date: 28.03.2024
Rev.03, Revision Date: -





Touchscreen interface
Modus Focused ESWT
Shock Waves

WHAT IS FOCUSED SHOCK WAVE THERAPY?

The focusing mechanism directs each shock to a specific point in the body. Separate heads can be used to provide the energy depth. Focused shock waves can target deeper tissues more precisely by propagating all of the energy within the tissue. This is why local pain points, chronic insertional tendinopathies, bone stress injuries, and deep trigger points are best treated with focused shock waves. Patients who cannot tolerate radial treatments for acute injuries can also going to benefit from focused shock wave therapy.



Modus Focused ESWT
Handpiece

> MODUS FOCUSED ESWT SHOCK WAVE THERAPY SYSTEM

25
LEVELS OF
POWER

> Modus Focused ESWT Shock Wave System is a non-invasive treatment method based on focusing shock waves on the desired area of the body via a liquid-filled silicone cap. This method increases vascularization in the area affected and enables the body's healing mechanisms to come into play.

> Modus Focused ESWT provides impulses up to 4 Hz and 0.25mJ.

> The device provides ease of use with its colored touch screen technology. In addition, the parameters set during the treatment can be easily followed on the device screen and can be changed as desired during the treatment.

> Modus Focused ESWT device provides archive support to the user with its patient registration and follow-up menu.

>The system provides video and written support to the user with the ready-made treatment programs in its content. Different caps are available for different treatments.

> When the number of shock which set at the beginning of the treatment with Modus Focused ESWT are reached, the system automatically stops and the user can intervene as desired.

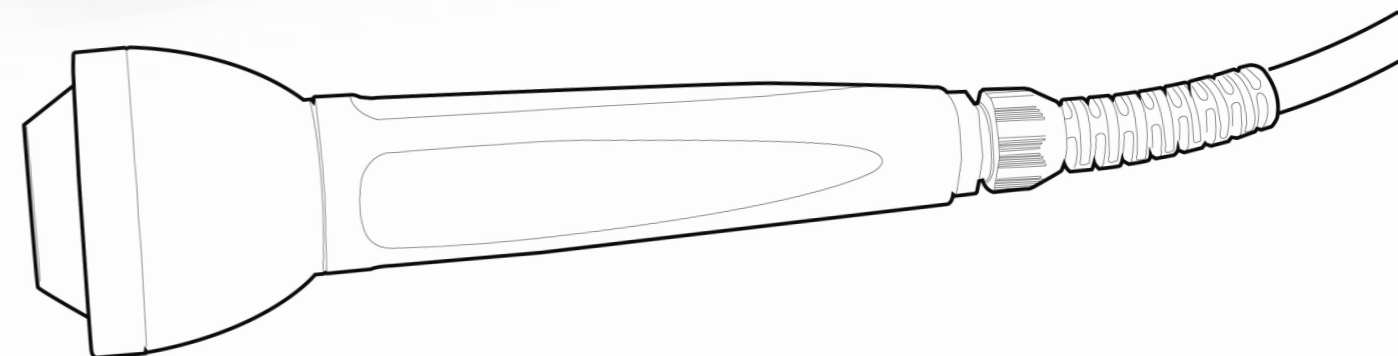

MODUS FOCUSED ESWT HANDPIECE FEATURES

- > Full energy transmission to the selected anatomical region
- > Easy and fast use that does not tire the operator
- > Easy mobility
- > Maintenance-free handpiece
- > Different applicator head membrane options with easy replacement according to use



> PROVIDES MORE ENERGY
ON DEEPER TISSUES



Higher Energy Output



High Energy Depth



Fast and Effective
Treatments

F-50 Head

Penetration Depths

- 20 mm
- 30 mm
- 50 mm
- 70 mm

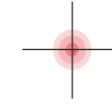

Usage Area: Epin Calcanei, Achillodynia, Bone and Stress Fractures, Calcified Tendonitis Of Shoulder, Patellar Type Syndrome...

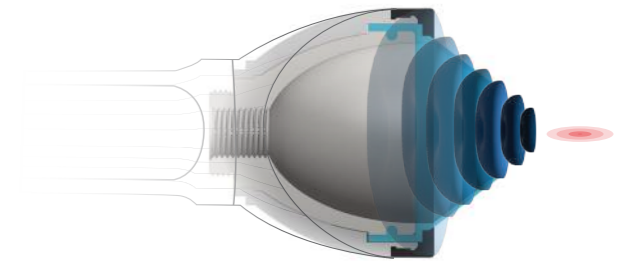

F-60 Head

Penetration Depths

- 30 mm
- 40 mm
- 60 mm

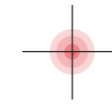

Usage Area: Myofascial Trigger Points, Plantar Fasciitis, Bone and Stress Fractures, Epin Calcanei, Patellar Type Syndrome...

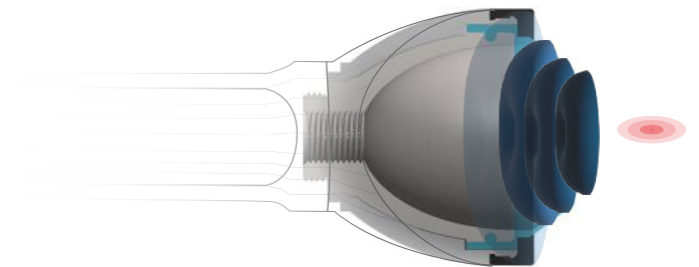

F-80 Head

Penetration Depths

- 40 mm
- 50 mm
- 80 mm

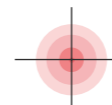

Usage Area: Achillodynia, Bone and Stress Fractures, Calcified Tendonitis Of Shoulders, Patellar Type Syndrome...

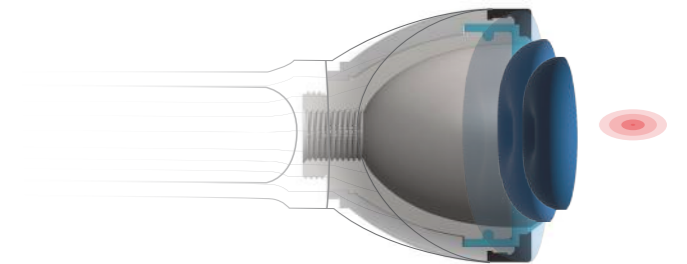

F-L50 Head

Penetration Depths

- 50 mm



Usage Area: Achillodynia, Carpal tunnel Syndrome, Chronic Pelvic Pain, Osteitis Pubis-Inguinal Pain, Patellar Type Syndrome...

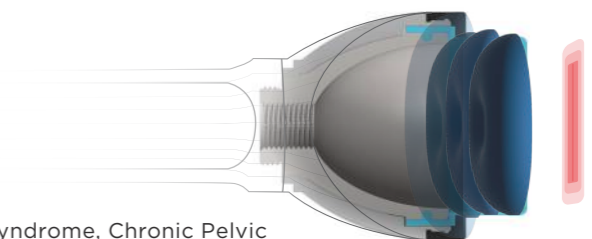

> WHAT IS THE SHOCK WAVE THERAPY ?

The application method of extracorporeal shock wave therapy is a frequently preferred method in the fields veterinary medicine, neurology, urology, cardiology, sports medicine, aesthetics, and especially in orthopedics and physical therapy. One of the advantages of this system is that it promotes faster tissue healing by increasing revascularization, collagen synthesis, and oxygenation in the application area. Furthermore, it develops less viscous tissue so that it is mechanically stronger.

With the non-invasive principle of the system, the desired treatment can be performed without the need for surgery.

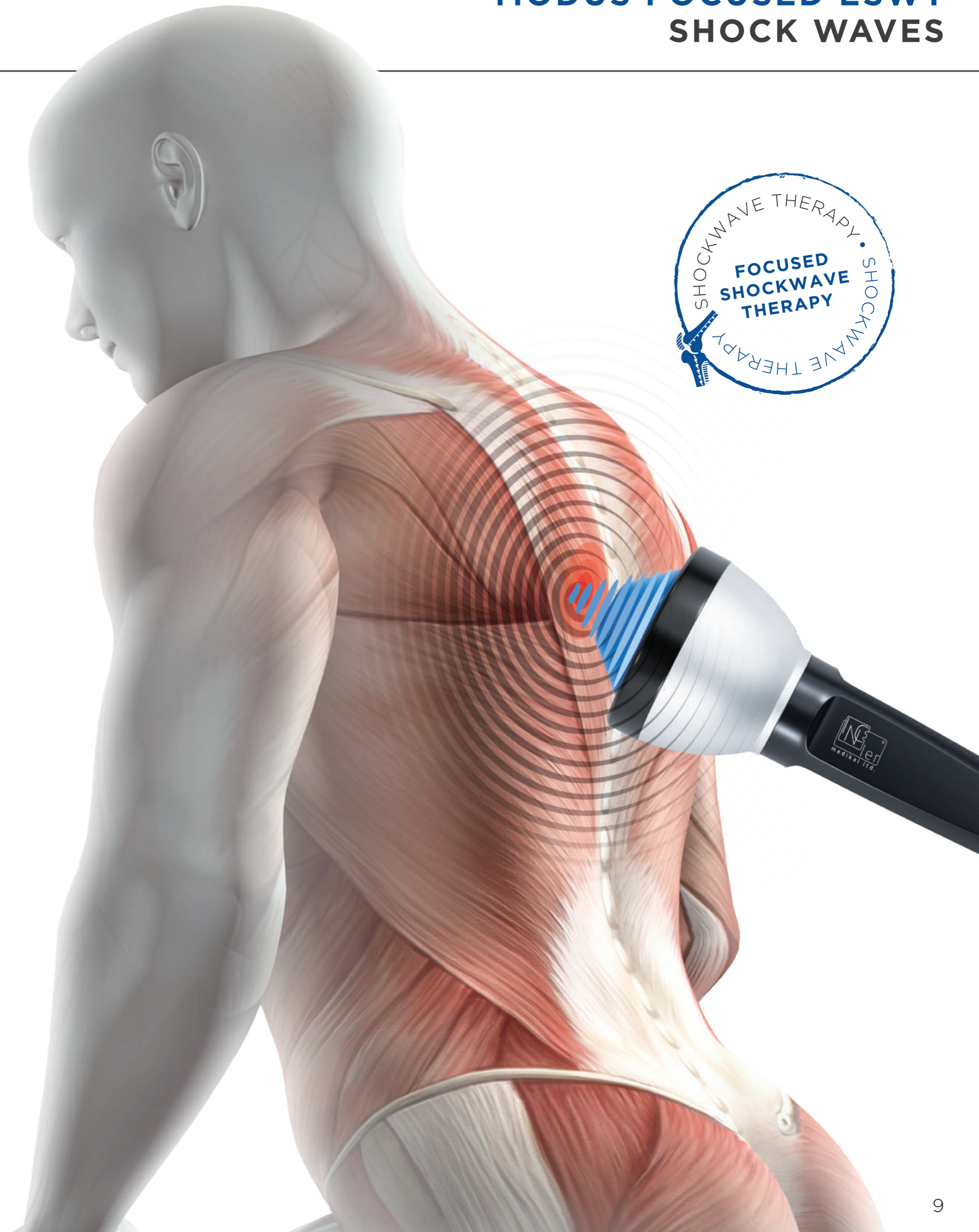



EPIN CALCANEI

A heel spur is a bone-like calcium deposit that forms between the heel bone and the arch of the foot. It often starts in the front of the heel and then affects other parts of the foot. It is often the result of prolonged tension in muscle and connective tissue. Repetitive stress from walking, running or jumping on hard surfaces is a common cause of heel spurs. Inflammation symptoms such as pain, swelling, temperature increase are seen in the anterior part of the heel. With ESWT treatment, pain relief is provided by eliminating the symptoms of pain and increasing the load capacity.



PLANTAR FASCIITIS

Plantar fasciitis is a painful foot disease that occurs as a result of inflammation of the sole and heel of the foot due to excessive stretching or use of the connective tissue called plantar fascia. Repetitive stress on the plantar fascia can cause mild ligament tears, which can cause discomfort, swelling and make walking difficult. It is one of the most common causes of heel pain, it can usually affect middle-aged women, men, people who stand up frequently or those who play sports. It is seen with swelling of the thick tissue that connects the sole of the foot to the toes. Plantar fasciitis often causes sharp pain with first steps in the morning. As the person moves, the pain usually subsides, but may return when standing or sitting for a long time and then getting up. In soft tissue sessions of ESWT treatment, the application time is approximately 5-20 minutes and 3-4 sessions are performed.



TIBIAL STRESS SYNDROME

Runner's leg syndrome or "medial tibial stress syndrome" is a condition of severe and throbbing pain seen on the inner surface of the shinbone in people who do extreme sports or are new to sports related to exercise. Slight swelling in the leg and pain occur when pressing the bone with a finger. It is often seen after excessive running. With ESWT Shock wave therapy, shock waves are given to the body so that the body's natural healing process is stimulated and pain is reduced.



ACHILLODYNIA

Achillodynia is a term used to describe a variety of severe Achilles tendon problems. Affected individuals experience pain in the tendons that run through the heel bone and calf muscles, and their ability to move the affected limb is limited. In mild cases, Achillodynia naturally goes away within a few days. Achilles tendon pain if it persists for a long time is considered a sign of overstretching. Therefore, Achillodynia is a common diagnosis among athletes and is considered an injury. Degenerative changes caused by inappropriate mechanical stress or prolonged excessive stretching can affect Achillodynia. As the structure of the tendon changes, its blood and oxygen supply may also be affected, which can affect the healing process. Tendons gain mobility faster, more successfully and permanently than desired with Modus shock wave therapy.



CALCIFIED TENDINITIS

Calcific tendinitis is described as one of the most common causes of shoulder pain. Tendinitis is the inflammation and irritation of the fibrous tissues called tendons that attach the muscles to the bones. It can occur in any tendon in the body, and calcium deposits form. This condition causes pain in the affected area. It is frequently seen in the shoulder, knee, wrist, elbow and ankle. Calcific tendinitis manifests itself with severe pain in the shoulder region. These pains occur especially in the evening and at night and can also limit mobility. Prolonged pain and inactivity can cause muscle weakness and weakness. With ESWT treatment, the release of pain-reducing substances is increased by changing the biochemistry of the environment.

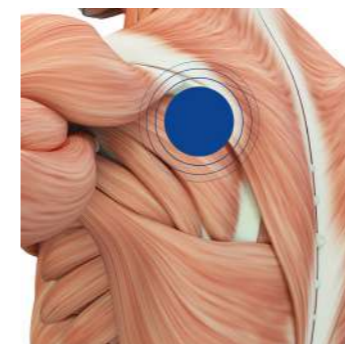

IDIOPATHIC LOW BACK

Lower back pain without sciatica, stenosis, or serious spinal deformation is common. There are different types of pain. For example, radicular pain spreads below the knee and distant dermatomes can be felt under it. The reason for this is thought to be nerve root-related disorders. Pseudoradicular pain is not diffused below the knee and is thought to be associated with local proximal disorders that do not affect any nerves or nerve roots. With shock wave therapy, narrowing of the affected muscle fibers, dysfunctions and stimulation of metabolic activity are eliminated.



**LATERAL EPICONDYLITIS -
MEDIAL EPICONDYLITIS**

Radial and ulnar humeral epicondylitis are two conditions that involve pain and inflammation in the elbow. These are known as tennis elbow (lateral epicondylitis) and golfer's elbow (medial epicondylitis), respectively. Tennis elbow is a condition caused by overuse of the muscles and tendons of the forearms, which connect to the lateral epicondyl of the humerus bone in the elbow. Similarly, golfer's elbow is a condition that affects the inside of the elbow. This is caused by overuse of the muscles and tendons of the forearms, which connect to the medial epicondyla of the humerus bone. Radial ESWT has been shown to be effective in reducing pain and increasing function in patients with radial humeral epicondylitis. It is usually applied in a series of sessions over several weeks and takes about 10-15 minutes per session. During treatment, the patient may experience mild to moderate discomfort, but is generally well tolerated. After treatment, patients may feel some pain or bruising in the treated area, but these side effects usually resolve within a few days.



PSEUDORADICULAR LOW - BACK

Trigger point: It is the painful muscle area where the sensitivity in the area where the normal functional relationship of muscle fibers is disrupted has a regional distribution character. It affects the muscle by making it weak and tight. It causes strong contractions in the muscle group they are in. It causes especially shoulder, arm and lower back pain. The muscles, which are in constant contraction, also apply pressure to the bones, causing these symptoms to occur in the adjacent joints and impairing the blood circulation of the adjacent area. With the decrease of oxygen in the circulation and the nutrients needed by the metabolism, metabolic wastes begin to accumulate. Low oxygen levels and metabolic wastes starts pain on lower back.



CARPAL TUNNEL SYNDROME

Carpal tunnel syndrome; It is a disease that causes numbness, tingling and pain in the hand and forearm. This condition occurs when the median nerve, one of the main nerves in the hand, is compressed as it passes through the wrist. The tendons that provide the movement of the fingers and the median nerve are located in the canal. The median nerve allows the fingers to feel and make certain movements. If the nerve is under pressure in the canal, carpal tunnel syndrome occurs. ESWT treatment is a preferred treatment method to prevent compression of the nerves in the region and to relieve numbness, tingling and pain.



TROCHANTERIC BURSITIS

Trochanteric bursitis is a condition that causes pain in the outer hip area. The hip joint is surrounded by bursae, which are several small fluid-filled vesicles that help reduce friction and cushion the joint. Trochanteric bursitis occurs when the bursae on the outside of the hip near the greater trochanter becomes inflamed. This inflammation may result from repetitive activities such as running, cycling, or climbing stairs, or may result from direct trauma or injury. Symptoms of trochanteric bursitis may include pain, tenderness, and swelling in the hip area, as well as difficulty lying on the affected side or difficulty walking or climbing stairs. Radial ESWT works effectively in the case of trochanteric bursitis. It has been observed that most patients receiving shock wave therapy experience similar pain reduction with other preventive treatments and improvement based on how much better the affected area moves. It has the advantage of being as effective as surgery and not risking infection.



DIABETIC FOOT ULCERS

Diabetic foot ulcers (DFUs) are among the most common foot disorders with ulceration, infection, and gangrene, that may ultimately lead to lower extremity amputation. The goals of treatment include the control of diabetes and proper shoe wear. Effective therapy and appropriate foot care are important in wound healing in DFUs. Recently, extracorporeal shockwave therapy (ESWT) was reported to significantly promote and accelerate the healing of complex soft tissue wounds compared to the standard methods of treatment in DFUs. ESWT showed positive results in short-term and long-term outcomes in diabetic patients suffering from foot ulcers.



BROKEN FRACTURE

Patients show symptoms such as pain, cyanosis, swelling, deformity, impaired symmetry, inability to move, and limitation of movement due to post-traumatic fractures, dislocations and sprains in joints, bones and adjacent tissues. ESWT has an effect on fracture healing, in bone and cartilage tissues. It has been observed that in non-healing fractures (pseudoartosis), the application of shock waves around the fracture increases osteoblastic activity and stimulated the periosteum, thus accelerating healing. Modus ESWT transmits the shock waves directly to the focal point.



Modus Focused ESWT®
Arm System
Arms system is an optional feature.

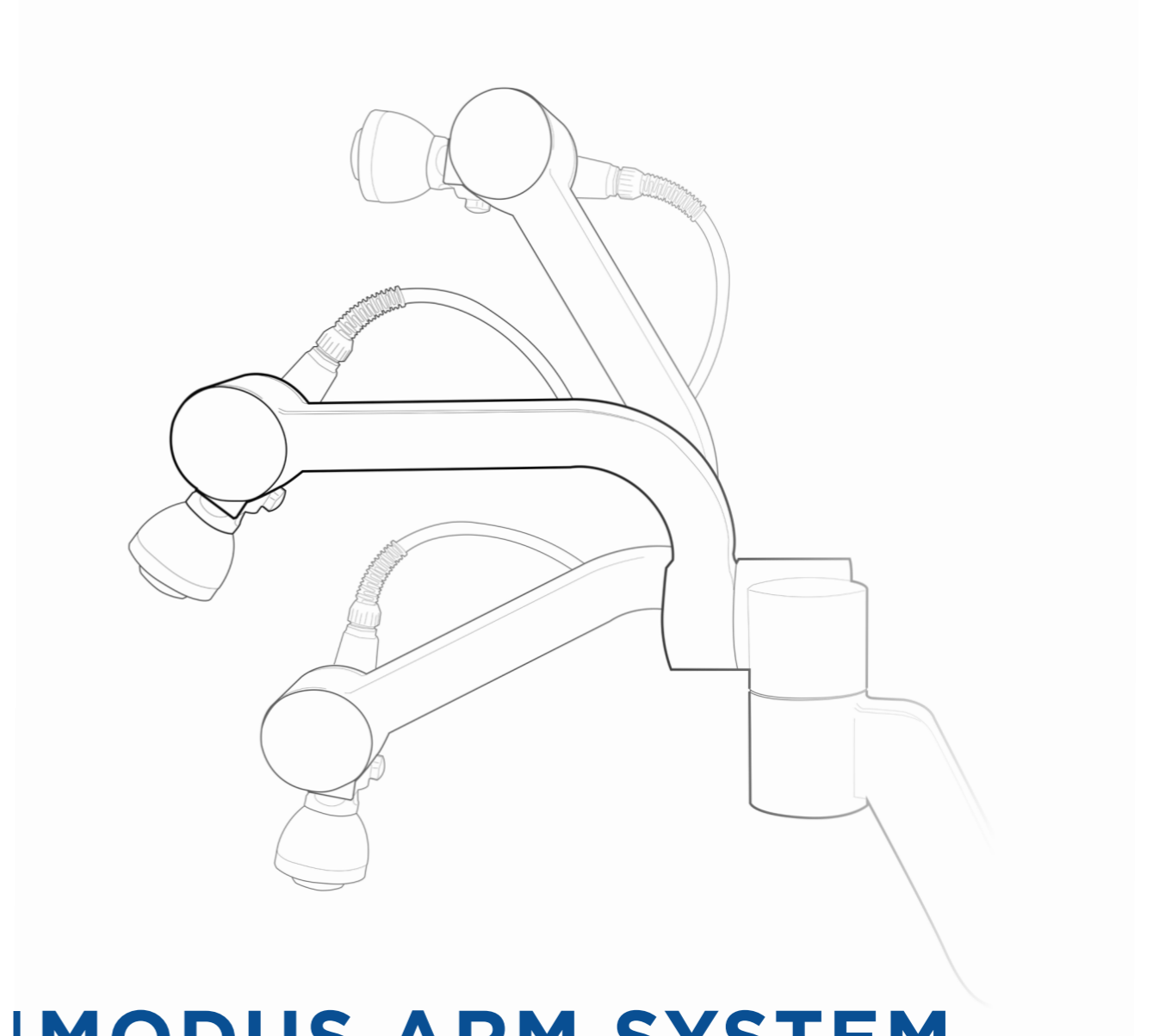

MODUS ARM SYSTEM

An optional arm that can be added to Modus Focused ESWT provides ease of movement to the physician. This way the physician does not have to hold the handpiece for a long time during the treatment. In addition, it also minimizes the physician's patient contact. The arm can be moved in 3 axes. There are two buttons on the device for the arm. With help of these buttons, the device can move up and down. This way, positioning can be made according to the patient and their chair. The angle of the arm can also be adjusted manually.

Technical Specifications

Manufacturer	İnceler Medikal Sağlık Hizmetleri San. Tic. Ltd.
Model	Modus Focused ESWT
Quality and Electrical Safety Classification	According to EN 60601-1 Class I Type B According to EN 93/42 MDD Class IIb FDA Registered Manufacturer IEC 60601-1 IEC 60601-1-2
Working Principle	Electrohydraulic
User Modes	Continuous, Burst, Auto
Treatment Start/ Stop	Main Unit Button, Handpiece Button (Optional), Foot Pedal (Optional)
Dimensions	116 mm x 387 mm x 316 mm (Main Unit) 917 mm x 512 mm x 410 mm (Trolley including)
Weight	55 kg
Voltage & Frequency	110 - 240 ±% 10 VAC & 50/60 Hz
Frequency	1 - 4 Hz
Memory	3 User Defined Treatment Protocol
Applied Power	0,01 mJ/mm ² - 0,25 mJ/mm ²
Display	Touch Screen
Electrode Lifespan	50K - 70K Shock
Operating Environment	10° C ≤ Temperature ≤ 40° C 30% Rh ≤ Humidity ≤ 80% Rh
Storage Environment	-10° C ≤ Temperature ≤ 50° C 20% Rh ≤ Humidity ≤ 90% Rh

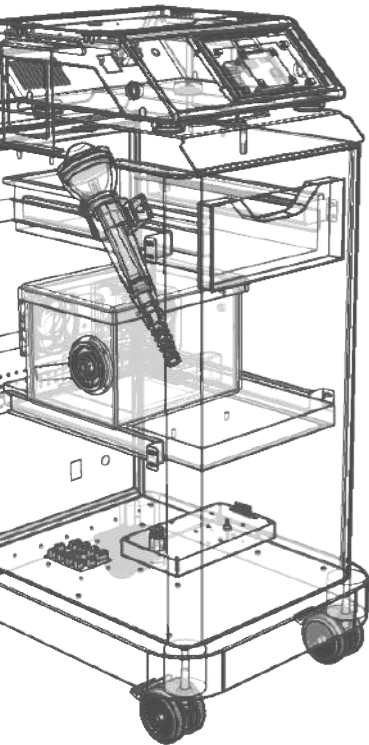

> PAIN TREATMENT WITH MODUS FOCUSED ESWT FAST AND EASY



1. MEDICAL EXAMINATION
Locate the painful area.



2. SIGN
Mark the area.



3. APPLY GEL
Apply the gel to the tissue
to conduct shock waves



4. APPLY SHOCK WAVES
Apply the applicator firmly to
the painful area on the skin.



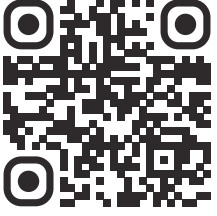

Orthopedics

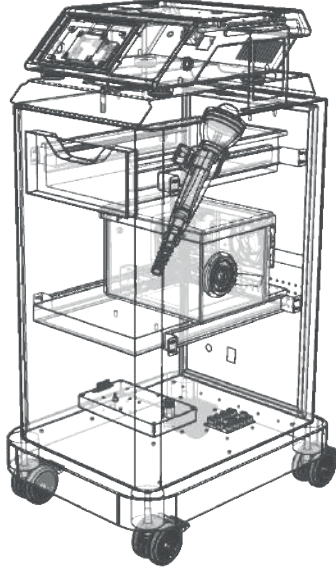

Technology For Health

WWW.INCELERMEDIKAL.COM

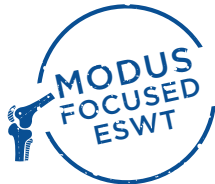

İnceler Medikal Ltd.
İvedik OSB Mah. 1472. Cad.
No: 120 Yenimahalle
Ankara/Türkiye

tel: +90 312 255 3346
sales@incelermedikal.com

MODUS FOCUSED